

CTM-680

CDMA 450MHz Module

H/W Operation Manual

CTM-680-ver.1.1
Mar, 2012

R&D Center

CELOT Wireless Co., Ltd (Korea)
#307-2, Kami-Dong, Hanam City,
Kyunggi-Do, 465-200, Korea
Tel : +82-31-383-2297
Fax :+82-31-385-2297

Contents

1. INTRODUCTION.....	4
1.1. OVERVIEW	4
1.2. CTM-680 GENERAL SPECIFICATIONS	4
1.3. Receive Specifications	4
1.4. Transmit Specifications.....	5
1.5. MSM6800A Chipset Highlights.....	5
1.6. Standards	5
2. PIN DESCRIPTIONS.....	6
2.1. PIN ASSIGNMENT.....	6
2.2. PIN DESCRIPTION	7
3. EXAMPLE MODULE APPLICATION CIRCUIT.....	9
3.1. POWER MANAGEMENT CIRCUIT.....	9
3.2. UIM CIRCUIT DESIGN.....	10
3.3. EAR-MIC CIRCUIT DESIGN	10
3.4. RS232C DATA LINE CIRCUIT DESIGN	11
4. ELECTRICAL CHARACTERISTICS.....	12
4.1 <i>Absolute Maximum Ratings</i>	12
4.2 <i>Recommended Operating Conditions</i>	12
4.3 <i>Power consumptions</i>	12
5 MECHANICAL DIMENSIONS.....	13
5.1 OUT LINE.....	13
5.2 APPLICATION FOR CUSTOMER PCB BOARD	13
6 CONNECTORS	14
6.1 INTERFACE CONNECTOR (60 PIN).....	14
6.2 RF SWITCH AND CONNECTOR	16

About this Document

This document provides hardware interface and information for the CTM-680 CDMA Module. The manual is divided into the following chapters.

Chapter 1 : Introduction

This chapter introduces the CTM-680 device's basic feature and functions.

Chapter 2 : Pin Descriptions

This chapter lists each CTM-680 device pin and its function within the device.

Chapter 3 : Electrical Specifications

This chapter specifies the recommended operating conditions, DC voltage characteristics, and power estimations for the CTM-680 device.

Chapter 4 : Interface Description

This chapter details each subsystem or block within the CTM-680 device and how the subsystem or block interfaces to external peripherals.

Chapter 5 : Mechanical Dimensions

This chapter provides CTM-680 physical dimensions

Chapter 6 : Connectors

This chapter provides the information of 60-pin B-to-B connector and RF switch and/or RF connector.

1. Introduction

1.1. Overview

The CTM-680 is the next generation CDMA 450Mhz module product specifically designed for various CDMA embedded wireless applications. The compactness of the CTM-680 will be ideal for the FWT. And other Applications including Handset CTM-680 contains the complete features of Radio Frequency and base-band circuitry as well as firmware that fully compiled with CDMA 2000 1x RTT & IS-856 standards. The CTM-680 also provides the full scale and flexible interface with host devices for the various advanced applications by using AT commands.

The interface can be customized for the specific device upon customer's requirements.

1.2 CTM-680 General Specifications

Parameters	Descriptions
External Access	Code-Division-Multiple-Access (CDMA)
CDMA Protocol	IS-95 A/B, IS-98A, IS-126, IS-637A, IS-707A, IS-2000, IS-856
Data Rate	Down link : 3.1Mbps, Up Link : 1.8 Mbps max
Transmit/Receive Frequency Interval	10MHz
Vocoder	EVRC, 13kQCELP
RF technology	Zero Intermediate Frequency
Number of Channel	200FA(BW:1.23MHz)
Operating Voltage	VBATT_INT : +3.8V ±10%
	VEXT_DC : +4.5V±10%
Current Consumption	Stand by mode: Idle (110mA), Sleep (less than 1mA) Busy mode: About 600mA
Operating Temperature	-20°C ~ +50°C
Frequency Stability	±300Hz
Antenna	GSC Connector, 50ohm
Size	30 X 40 X 4mm with case
Weight	About 9g
External Interface	RS-232s, Digital/Analog Audios, Ringer External Reset Control, R-UIM, USB, GPIOs
User Interface Software	BREW support
Additional Function	GPS One position location solution USB interface

1.3 Receive Specifications

\	Descriptions
Frequency Range	462.5 ~ 467.475 MHz for "A" and 420.000 ~ 424.975 MHz for "L"
Sensitivity	Below -104 dBm
Interference Rejection	Single tone (-30dBm @900KHz): Below -101dBm Two tone (-43 dBm @900KHz and 1700KHz): Below -101dBm

Spurious Wave Suppression	Below -80dBc
Input Dynamic Range	-25 dBm ~ -104dBm

1.4 Transmit Specifications

Parameters	Descriptions
Frequency Range	452.5 ~ 457.475 MHz for "A" 410.000 ~ 414.975 MHz for "L"
Nominal Power	0.32 W (25.0dBm)
Minimum Controlled Output Power	Below -50dBm
Max Power Spurious	900KHz: Below -42dBc/30KHz 1.98MHz: Below -54dBc/30KHz

1.5 MSM6800A Chipset Highlights

Enhanced Processing power	a. ARM926EJS processor with Java accelerator b. Advanced QDSP4000 DSP cores
Radio-One ZIF Architecture Support	a. Saves board space b. Integrated solution
High Data Rates	a. CDMA2000 1xEVDO (IS-856) support b. Receive diversity on CDMA2000 1X and 1xEVDO systems
Multi-mode Solution	a. 1X / 1xEVDO / GPS b. Diversity RX

1.6 Standards

IS-95 A/B: Protocol Between MS & BTS

IS-96A: Voice Signal Coding

IS-98A: Base MS Function

IS-126: Voice Loop-Back

IS-637: Short Message Service

IS-707: Data Service

Built-in TCP/IP : AnyDATA proprietary software

IS-657 : packet data

IS-856 : packet data

2. Pin Descriptions

2.1. Pin Assignment

The interface of CTM-680 consists of most possible features with 60 pin connector.

GND	1	2	GND
UART1_TXD	3	4	UART1_RXD
UART3_TXD	5	6	UART3_RXD
RUIM_PCLK	7	8	/RUIM_PRESET
RUIM_PDATA	9	10	VREG_RUIM
/EAR_DET	11	12	MIC2_P
HPH_R	13	14	HPH_L
MIC1_P	15	16	EAR_10P
EAR_10N	17	18	AUX_PCM_CLK
AUX_PCM_DOUT	19	20	AUX_PCM_DIN
AUX_PCM_SYNC	21	22	POWER_ON
ISNS_P	23	24	USB_ID
CHG_CTL_N	25	26	USB_CTL_N
/TRST	27	28	RTCK
TDO	29	30	TDI
TMS	31	32	TCK
VREG_MSMP(2.6)	33	34	JTAG_RESOUT_N
PS_HOLD	35	36	BATT_ID
GPIO5, BUSY	37	38	GPIO9, SMS
GND	39	40	GND
UART1_RFT	41	42	UART1_CTS
UART1_RI	43	44	GPIO26, I2C_SDA
UART1_DTR	45	46	GPIO27, I2C_SCL
SPK_OUT_P	47	48	SPK_OUT_N
USB_DP	49	50	USB_DM
USB_VBUS_CON	51	52	VBATT_INT
VEXT_DC	53	54	VBATT_INT
VEXT_DC	55	56	VPH_PWR
GPIO11, IDLE	57	58	VPH_PWR
GND	59	60	GND

Figure 2-1. Pin-outs for CTM-680 Connector

2.2. Pin Description

Pin	Signal Name	Type	Pin Description
1	GND	V	Ground
2	GND	V	Ground
3	UART1_TXD	O	UART1 TX DATA
4	UART1_RXD	I	UART1 RX DATA
5	UART3_TXD	O	UART3 TX DATA
6	UART3_RXD	I	UART3 RX DATA
7	RUIM_PCLK	O	RUIM CLK
8	RUIM_RESET	O	RUIM RESET
9	RUIM_DATA	I/O	RUIM DATA
10	VREG_UIM	V	RUIM VREG
11	EAR_DET	I	EAR KEY DETECT
12	MIC2P	O	EAR MIC OUT
13	HPH_R	O	EAR JACK (+)
14	HPH_L	O	EAR JACK (-)
15	MIC1P	O	External MIC
16	EAR_1OP	O	Receiver (+)
17	EAR_1ON	O	Receiver (-)
18	AUX_PCM_CLK	O	Digital Audio
19	AUX_PCM_DOUT	O	Digital Audio
20	AUX_PCM_DIN	I	Digital Audio
21	AUX_PCM_SYNC	O	Digital Audio
22	POWER_ON	I	POWER ON/OFF
23	ISNS_P	I	Charger
24	USB_ID	I	USB
25	CHG_CTL_N	O	Charger
26	USB_CTL_N	O	Charger
27	/TRST	I/O	JTAG
28	RTCK	I/O	JTAG
29	TDO	I/O	JTAG
30	TDI	I/O	JTAG
31	TMS	I/O	JTAG
32	TCK	I/O	JTAG
33	VERG_MSMP(2.6)	V	POWER

34	JTAG_RESOUT_N	O	JTAG
35	PS_HOLD	O	External RESET
36	BATT_ID	V	Battery Detect
37	GPIO_INT05/BUSY	O	LED -BUSY
38	GPIO_INT09/SMS	O	LED -SMS
39	GND	V	Ground
40	GND	V	Ground
41	UART1_RFR	O	UART1 – Ready for Receive
42	UART1_CTS	I	UART1 – Clear To Send
43	UART1_RI	O	UART1 – Ring Indicator
44	I2C_SDA	I/O	RESERVED
45	UART1_DTR	I	UART1 - Data to Ready
46	I2C_SCL	I/O	RESERVED
47	SPK_OUT_P	O	SPEAKER OUT (+)
48	SPK_OUT_N	O	SPEAKER OUT (-)
49	USB_DP	O	USB DATA (+)
50	USB_DM	O	USB DATA (-)
51	USB_VBUS_CON	I	USB DC POWER INPUT
52	VBATT_INT	I	INTERNAL BATTERY
53	VEXT_DC	V	EXTERNAL DC POWER
54	VBATT_INT	I	INTERNAL BATTERY
55	VEXT_DC	V	EXTERNAL DC POWER
56	VPH_PWR	V	POWER SUPPLY
57	GPIO11/IDLE	O	LED - IDLE
58	VPH_PWR	V	POWER SUPPLY
59	GND	V	Ground
60	GND	V	Ground

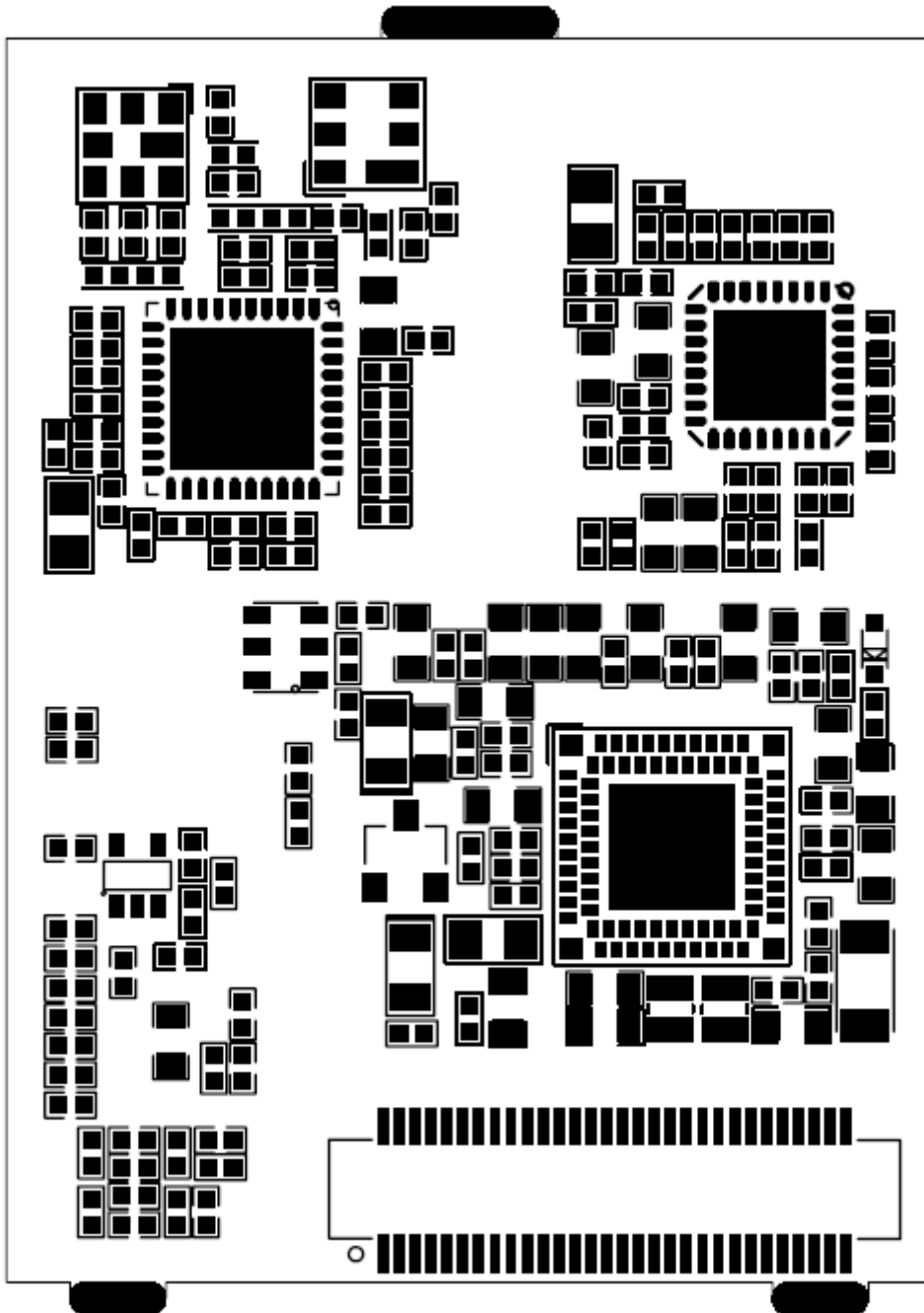

3. Example Module Application Circuit

3.1. Power Management Circuit

1. Input DC Power 4.0V(3.7~4.2V) to No.53 pin - for MSM booting
2. Input DC Power 4.0V(3.7~4.2V) to No.56 pin - for MSM booting
3. Input DC Power 5.0V to No.51 Pin (USB_VBUS_CON) – for USB Operation
4. Connect GND

3.2. UIM Circuit Design

1. Connect No.9 Pin and RUIM_DATA Line
2. Connect No.7 Pin and RUIM_CLK Line
3. Connect No.8 Pin and RUIM_RESET/ Line
4. Connect No.10 Pin and VERG_RUIM Line

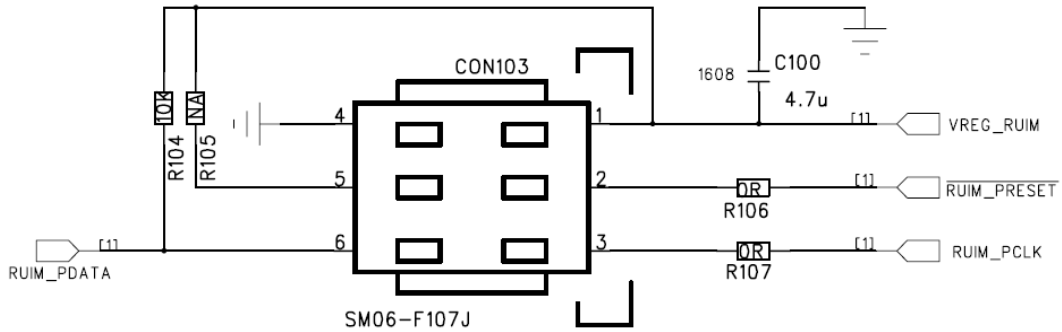

UIM Connector Pin Name	Pin Description
1	VERG_RUIM
2	RUIM_PRESET
3	RUIM_PCLK
4	GND
5	NA
6	RUIM_PDATA

3.3. Ear-Mic Circuit Design

1. Connect No.11 Pin and EAR_SENSE (EAR_DETECTED) Line
2. Connect No.13 Pin and HPH_R Line
3. Connect No.14 Pin and HPH_L Line
4. Connect No.12 Pin and MIC2_P

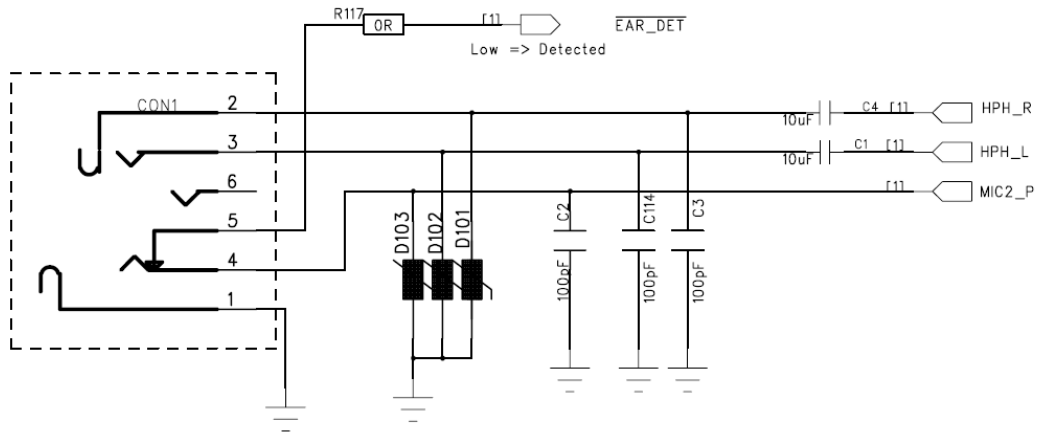

3.4. RS232C Data Line Circuit Design

1. Connect No.3 (UART1_TXD).
2. Connect No.4 (UART1_RXD)
3. CTM-680 use 2-wired connection. This below reserved.
4. Connect No.42 (UART1_CTS).
5. Connect No.41 (UART1_RFR).
6. Connect No.45 (UART1_DTR).

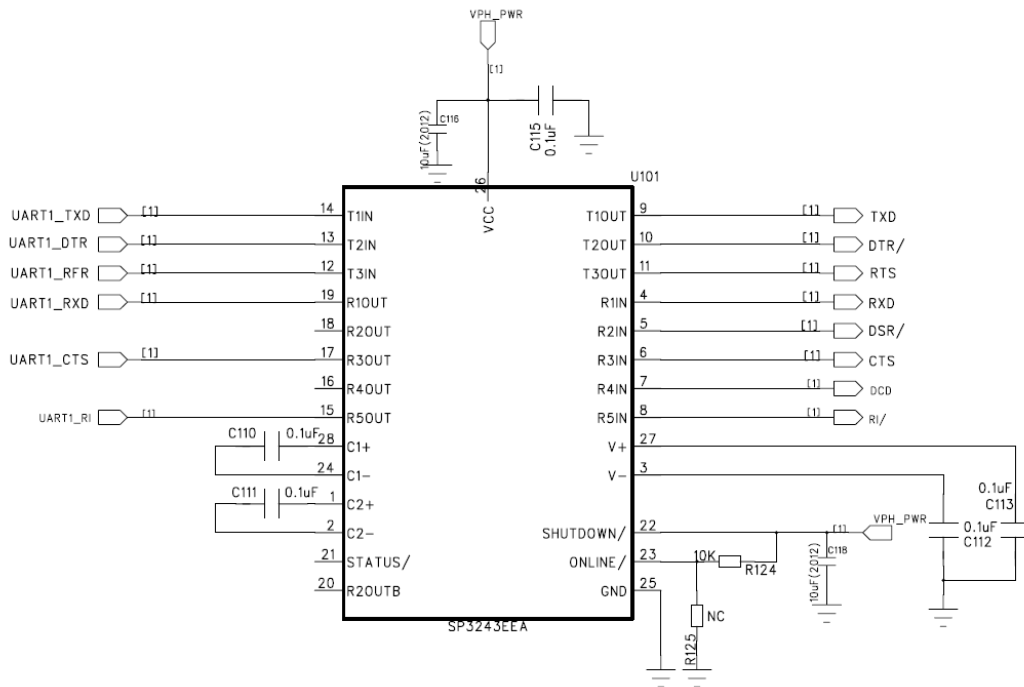

4. Electrical Characteristics

4.1 Absolute Maximum Ratings

Operating the CTM-680 under conditions that exceed those listed in Table 3-1 may result in damage to the module. Absolute maximum ratings are limiting values, and are considered individually, while all other parameters are within their specified operating ranges.

Table 4-1. Absolute Maximum Ratings

Symbol	Parameter	Min	Max	Unit
T _S	Storage temperature	-30	+85	°C
V _{EXT}	Power supply voltage	-0.5	5	V
V _{USB}	USB supply voltage (USB_VBUS)	-	6.5	V
V _{ESD}	Electrostatic discharge voltage*	-	TBD	V

(* : Human Body Model)

4.2 Recommended Operating Conditions

Table 4-2. Recommended Operating Conditions

Symbol	Parameter	Min	Max	Unit
T _A	Operating temperature	-25	+60	°C
V _{EXT}	Power supply voltage	3.7	4.2	V
V _{USB}	USB supply voltage (USB_VBUS)	4.0	5.2	V

4.3 Power consumptions

Table 4-3. Current Consumptions

Symbol	Parameter	Min	Max	Unit
I _{EXT_MAX}	Max current in conversation mode	-	620	mA
I _{EXT_SLEEP}	Sleep current in Stand-by mode	-	2	mA

5 Mechanical Dimensions

5.1 Out Line

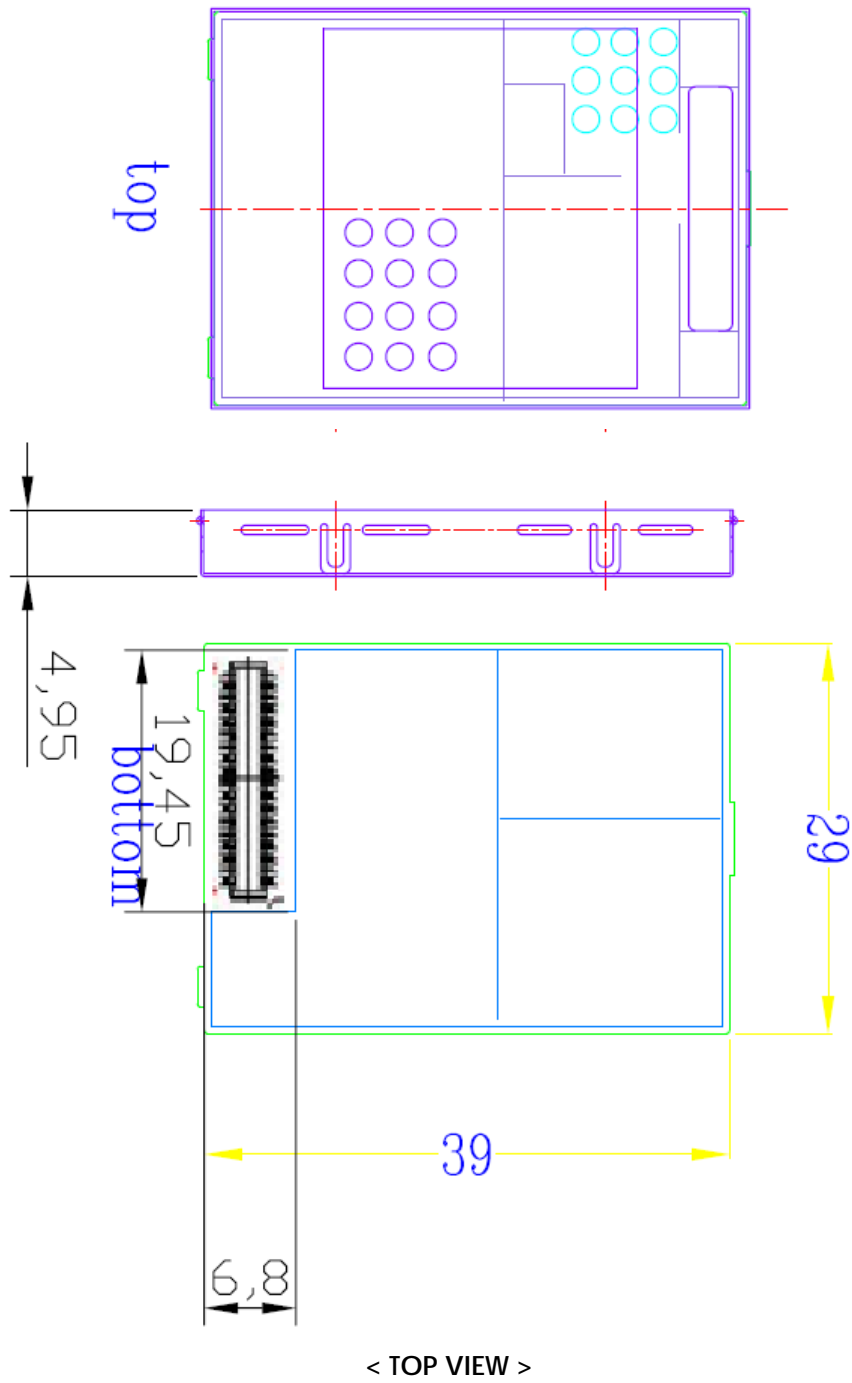

5.2 Application for Customer PCB Board

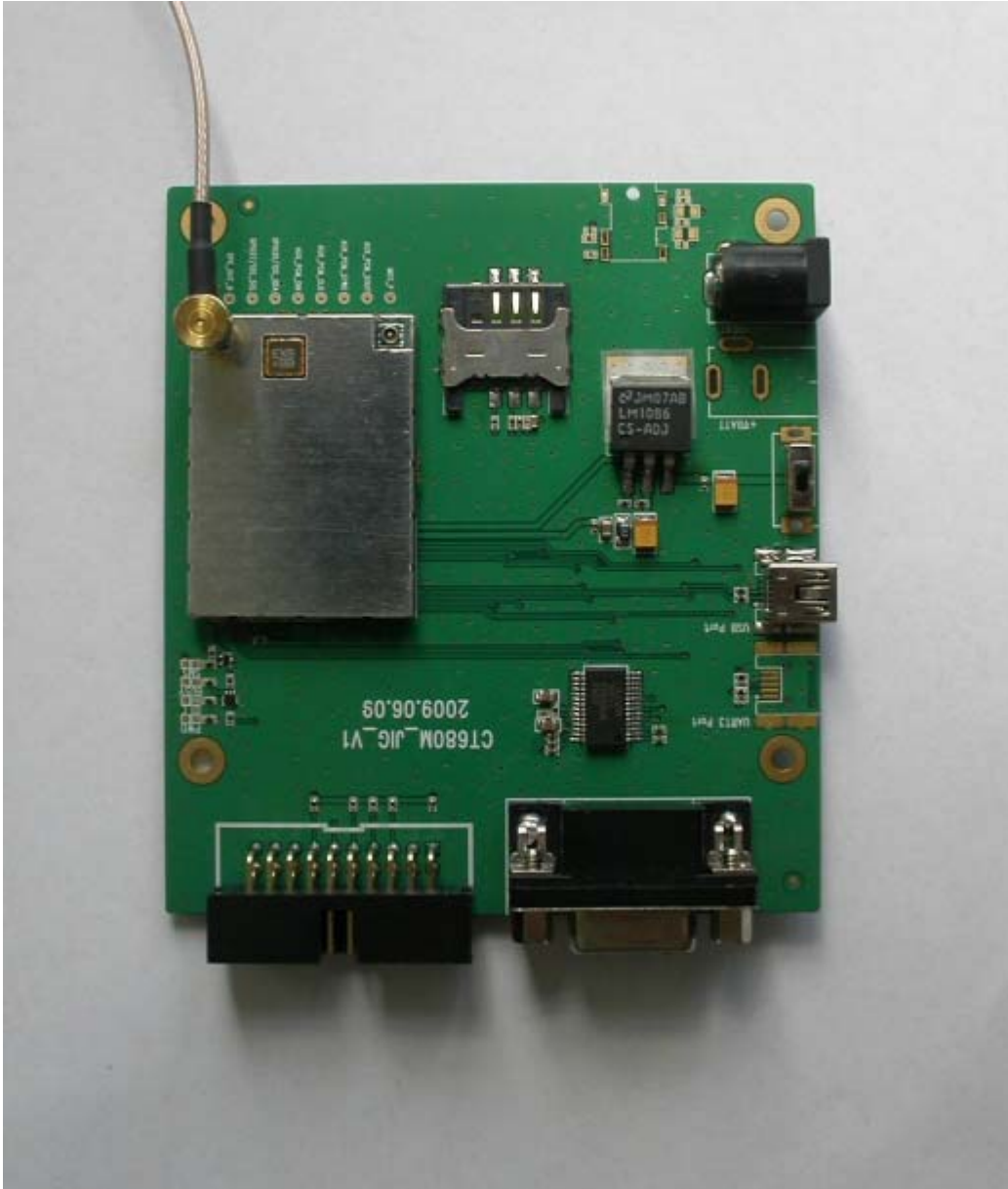

6 Connectors

6.1 Interface Connector (60 pin)

Table 6-1. CTM-680 Interface Connectors

Vendor	Connectors Part Number
NAIS	Plug : LWBP05-xxST
	Receptacle : LWBP05-xxSH

Note. The receptacle is mounted in host device because the plug is in bottom side of the CTM-680.

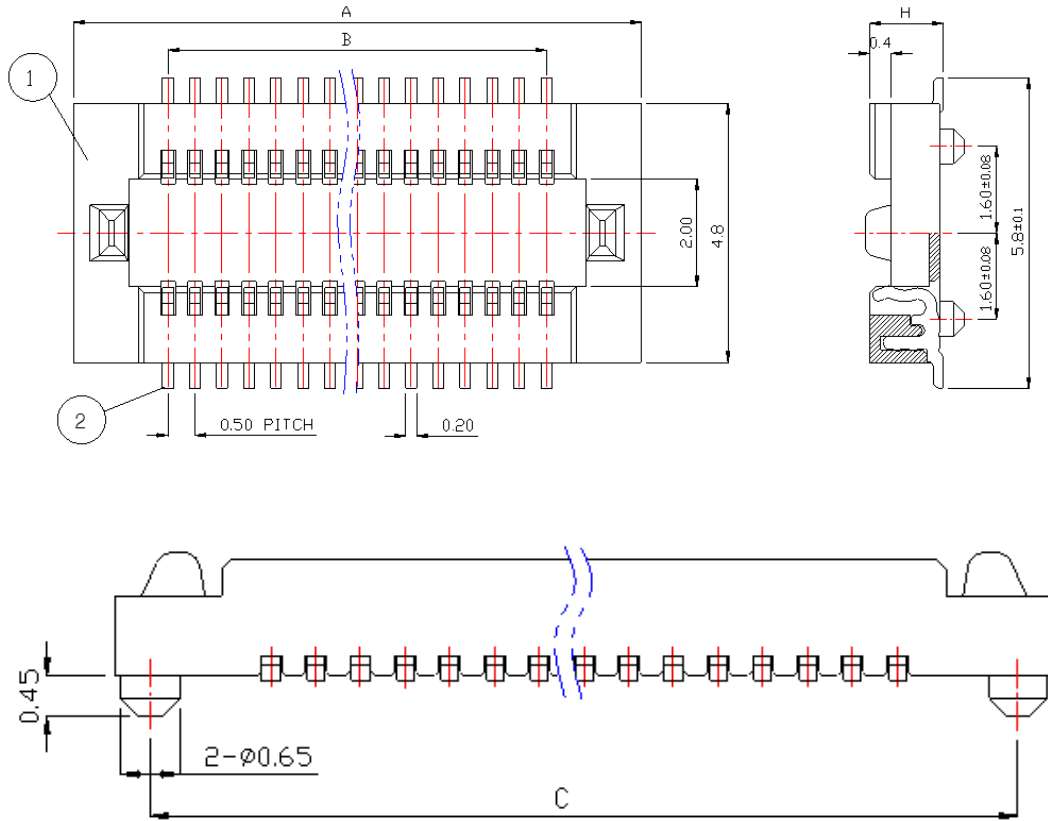

A	18.00	
B	14.50	
C	17.20	
H=1.5	Socket	1.35
	Plug	1.25

Figure 6-1. 60Pin Connector Receptacle

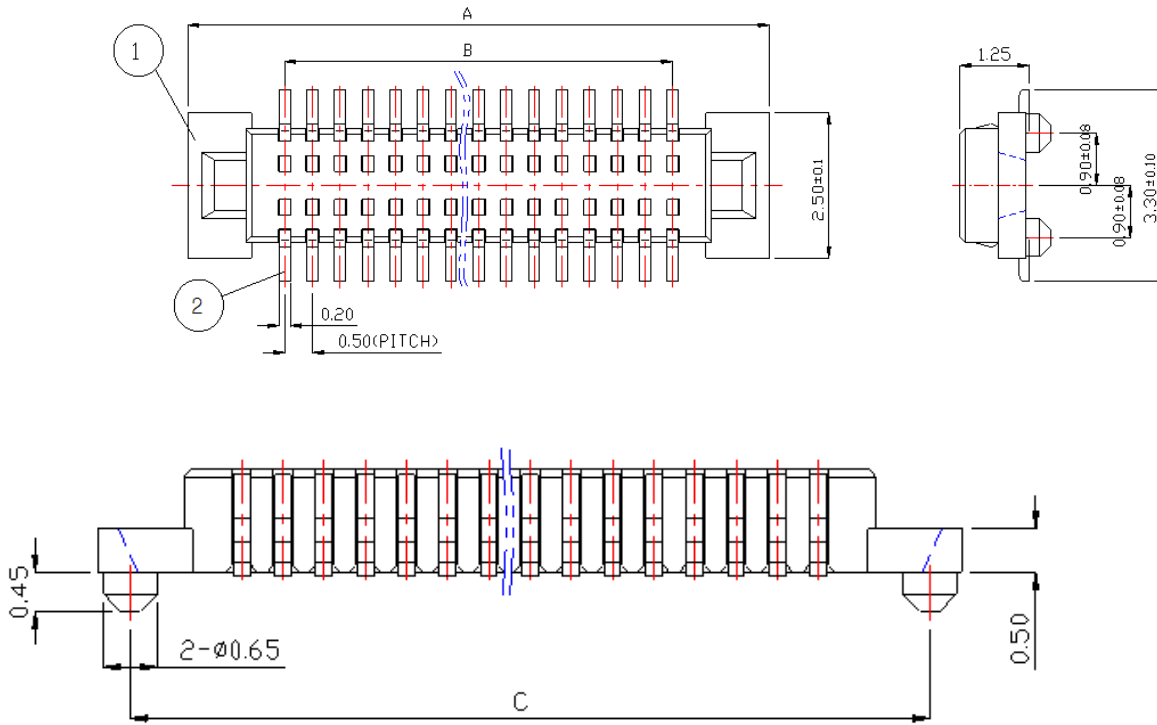

A	18.00	
B	14.50	
C	17.20	
H=1.5	Socket	1.35
	Plug	1.25

Figure 6-2. 40Pin Connector Plug

6.2 RF Switch and Connector

The MCM-620 has a RF coaxial connector or a RF switch or both in Table 6-2 for the connection between an antenna or the host device and the CTM-680.

Table 6-2. RF Coaxial Connector

Part Description	Part Number	Vendor
RF Coaxial Connector	MM9329-2700B	Murata
RF Switch	MM8430-2600	Murata

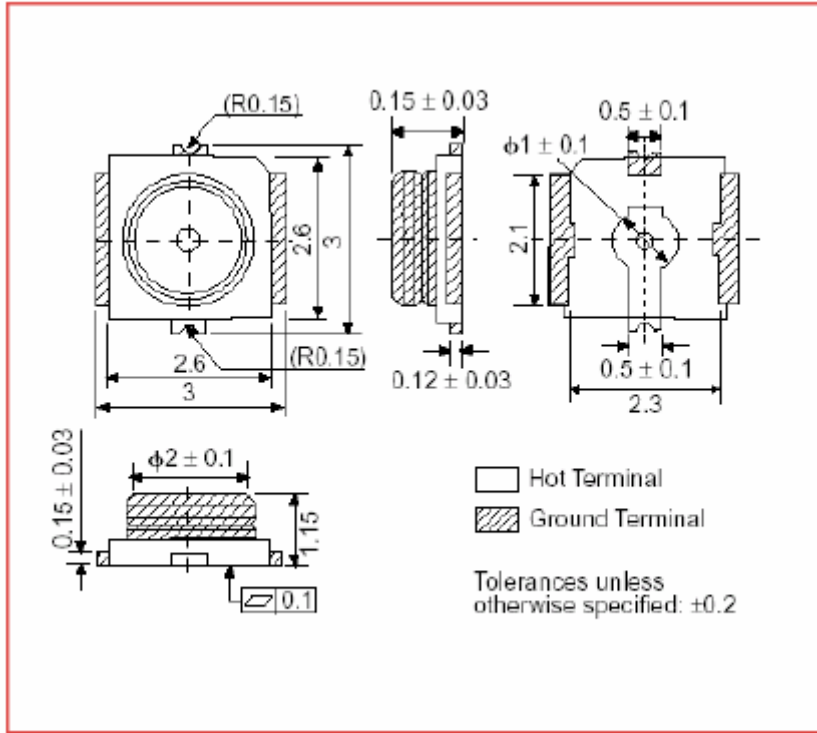

Figure 6-2 RF Connector