

SIEMENS

MC35i Terminal

Siemens Cellular Engine



Hardware Interface Description

Version: 01.02a
DocID: MC35i T HD v01.02a

Wireless Modules

Document Name: **MC35i Terminal Hardware Interface Description**

Version: **01.02a**
Date: **08.07.2003**
DocId: **MC35i_T_HD_v01.02a**
Status: **Confidential / Released**

General notes

Product is deemed accepted by Recipient and is provided without interface to Recipient's products. The Product constitutes pre-release version and code and may be changed substantially before commercial release. The Product is provided on an "as is" basis only and may contain deficiencies or inadequacies. The Product is provided without warranty of any kind, express or implied. To the maximum extent permitted by applicable law, Siemens further disclaims all warranties, including without limitation any implied warranties of merchantability, fitness for a particular purpose and noninfringement of third-party rights. The entire risk arising out of the use or performance of the Product and documentation remains with Recipient. This Product is not intended for use in life support appliances, devices or systems where a malfunction of the product can reasonably be expected to result in personal injury. Applications incorporating the described product must be designed to be in accordance with the technical specifications provided in these guidelines. Failure to comply with any of the required procedures can result in malfunctions or serious discrepancies in results. Furthermore, all safety instructions regarding the use of mobile technical systems, including GSM products, which also apply to cellular phones must be followed. Siemens AG customers using or selling this product for use in any applications do so at their own risk and agree to fully indemnify Siemens for any damages resulting from illegal use or resale. To the maximum extent permitted by applicable law, in no event shall Siemens or its suppliers be liable for any consequential, incidental, direct, indirect, punitive or other damages whatsoever (including, without limitation, damages for loss of business profits, business interruption, loss of business information or data, or other pecuniary loss) arising out the use of or inability to use the Product, even if Siemens has been advised of the possibility of such damages. Subject to change without notice at any time.

Copyright notice

Transmittal, reproduction, dissemination and/or editing of this document as well as utilization of its contents and communication thereof to others without express authorization are prohibited. Offenders will be held liable for payment of damages. All rights created by patent grant or registration of a utility model or design patent are reserved.

Copyright © Siemens AG 2003

Trademark notice

MS Windows® is a registered trademark of Microsoft Corporation.

Contents

0	Document history	5
1	Introduction	6
1.1	References	6
1.2	Standards	7
1.3	Safety precautions	8
1.4	Terms and abbreviations.....	10
2	Key features of MC35i Terminal	12
3	Interface description	14
3.1	Overview	14
3.2	Block diagram of a GSM application	15
3.3	The MC35i GSM /GPRS engine.....	16
3.4	Operating modes	17
3.5	Terminal circuit.....	18
3.5.1	Power supply and On/Off control	19
3.5.1.1	Maximum number of turn/on & turn/off cycles	20
3.5.2	RTC	21
3.6	Upgrading MC35i Terminal firmware	21
3.6.1	RS-232 interface.....	21
3.6.2	Audio interface.....	23
3.6.3	Radio interface	26
3.6.4	SIM interface	27
3.6.5	Status LED	27
4	Mechanical characteristics and mounting advice	28
4.1	Attaching the terminal	29
5	Electrical and environmental characteristics	30
6	Full type approval	36
6.1	Restrictions	37
6.2	CE Conformity.....	37
6.3	EMC.....	37
7	List of parts and recommended accessories	38

Figures

Figure 1: Block diagram of a MC35i Terminal application (example).....	15
Figure 2: MC35i GSM engine	16
Figure 3: MC35i Terminal circuit block diagram.....	18
Figure 4: Female 6-pole Western plug for power supply, ignition, power down	19
Figure 5: Pin assignment RS-232 (D-Sub 9-pole female).....	21
Figure 6: Audio Western plug (4-pole female).....	23
Figure 7: Audio block diagram.....	23
Figure 8: Antenna connector circuit on MC35i module	26
Figure 9: Recommended antenna connector.....	26
Figure 10: Design drawing	28
Figure 11: Recommended screws	29
Figure 12: Attaching MC35i Terminal onto a top-hat rail.....	29
Figure 13: Reference equipment for approval	36

Tables

Table 1: Terms and abbreviations	10
Table 2: Key features	12
Table 3: Coding schemes and maximum net data rates over air interface	13
Table 4: Overview of operating modes	17
Table 5: Female 6-pole Western plug for power supply, ignition, power down	20
Table 6: 9-pole D-Sub (female) RS-232	22
Table 7: Audio modes	24
Table 8: Coding of the green status LED	27
Table 9: Mechanical characteristics.....	28
Table 10: Absolute maximum ratings	30
Table 11: Operating conditions.....	30
Table 12: Characteristics power supply.....	31
Table 13: Characteristics (requirements) On/Off control lines	32
Table 14: Characteristics (requirements) RS-232 interface	32
Table 15: Characteristics (requirements) audio interface	33
Table 16: AT adjustable parameters	34
Table 17: Air interface	35

0 Document history

Preceding document: "MC35i Terminal Hardware Interface Description" Version 01.02

New document: "MC35i Terminal Hardware Interface Description" Version **01.02a**

Chapter	Page	What is new
1.1	6	Added Application Note 24: Application Developers' Guide
1.2, 6	7, 36	MC35i Terminal now fully type approved and labeled with CE mark

1 Introduction

This document describes the hardware of the Siemens MC35i Terminal. The information are intended for users, developers or manufacturers who design and build cellular applications beyond the standard setup. The scope of this document includes interface specifications, electrical issues and mechanical characteristics of MC35i Terminal. It specifies standards pertaining to wireless applications and outlines requirements that must be adhered to for successful product design. The MC35i Terminal is a compact GSM modem for the transfer of data, voice, SMS and faxes in GSM networks. Industrial standard interfaces and an integrated SIM card reader allow using MC35i Terminal easily as a dual band GSM terminal. The functionality of the Terminal corresponds to the features of the MC35i module.

1.1 References

- [1] MC35i AT Command Set for MC35i and MC35i Terminal, Version 01.02a
- [2] Release Note, Version 01.02
- [3] Application Note 16: Upgrading MC35i Terminal firmware
- [4] Application Note 02: Audio Interface Design
- [5] Application Note 24: Application Developers' Guide
- [6] Remote Sat User's Guide
- [7] Multiplexer User's Guide
- [8] Multiplexer Driver Developer's Guide for Windows 2000 and Windows XP
- [9] Multiplexer Driver Installation Guide for Windows 2000 and Windows XP

Prior to using the GSM engine, be sure to carefully read and understand the latest product information provided in the Release Notes.

To visit the Siemens Website you can use the following link:

<http://www.siemens.com/wm>

1.2 Standards

MC35i Terminal has been approved to comply with the directives and standards listed below and is labeled with the CE conformity mark.

Directives

99/05/EC	Directive of the European Parliament and of the council of 9 March 1999 on radio equipment and telecommunications terminal equipment and the mutual recognition of their conformity, in short referred to as R&TTE Directive 1999/5/EC
89/336/EC	Directive on electromagnetic compatibility
73/23/EC	Directive on electrical equipment designed for use within certain voltage limits (Low Voltage Directive)
95/54/EC	Automotive EMC Directive

Standards of type approval

ETS 300 607-1	Digital cellular telecommunications system (Phase 2); Mobile Station (MS) conformance specification; (equal GSM 11.10-1=>equal 3GPP TS 51.010-1)
EN 301 511	V7.0.1 (2000-12) Candidate Harmonized European Standard (Telecommunications series) Global System for Mobile communications (GSM); Harmonized standard for mobile stations in the GSM 900 and DCS 1800 bands covering essential requirements under article 3.2 of the R&TTE directive (1999/5/EC) (GSM 13.11 version 7.0.1 Release 1998)
EN 301 489-7	V1.1.1 (2000-09) Candidate Harmonized European Standard (Telecommunications series) Electro Magnetic Compatibility and Radio spectrum Matters (ERM); Electro Magnetic Compatibility (EMC) standard for radio equipment and services; Part 7: Specific conditions for mobile and portable radio and ancillary equipment of digital cellular radio telecommunications systems (GSM and DCS)
EN 60 950	Safety of information technology equipment (2000)

Requirements of quality

IEC 60068	Environmental testing
DIN EN 60529	IP codes

1.3 Safety precautions

The following safety precautions must be observed during all phases of the operation, usage, service or repair of any cellular terminal or mobile incorporating MC35i Terminal. Manufacturers of the cellular terminal are advised to convey the following safety information to users and operating personnel and to incorporate these guidelines into all manuals supplied with the product. Failure to comply with these precautions violates safety standards of design, manufacture and intended use of the product. Siemens AG assumes no liability for customer failure to comply with these precautions.



When in a hospital or other health care facility, observe the restrictions on the use of mobiles. Switch the cellular terminal or mobile off, if instructed to do so by the guidelines posted in sensitive areas. Medical equipment may be sensitive to RF energy.

The operation of cardiac pacemakers, other implanted medical equipment and hearing aids can be affected by interference from cellular terminals or mobiles placed close to the device. If in doubt about potential danger, contact the physician or the manufacturer of the device to verify that the equipment is properly shielded. Pacemaker patients are advised to keep their hand-held mobile away from the pacemaker, while it is on.



Switch off the cellular terminal or mobile before boarding an aircraft. Make sure it cannot be switched on inadvertently. The operation of wireless appliances in an aircraft is forbidden to prevent interference with communications systems. Failure to observe these instructions may lead to the suspension or denial of cellular services to the offender, legal action, or both.



Do not operate the cellular terminal or mobile in the presence of flammable gases or fumes. Switch off the cellular terminal when you are near petrol stations, fuel depots, chemical plants or where blasting operations are in progress. Operation of any electrical equipment in potentially explosive atmospheres can constitute a safety hazard.



Your cellular terminal or mobile receives and transmits radio frequency energy while switched on. Remember that interference can occur if it is used close to TV sets, radios, computers or inadequately shielded equipment. Follow any special regulations and always switch off the cellular terminal or mobile wherever forbidden, or when you suspect that it may cause interference or danger.



Road safety comes first! Do not use a hand-held cellular terminal or mobile when driving a vehicle, unless it is securely mounted in a holder for handsfree operation. Before making a call with a hand-held terminal or mobile, park the vehicle.

Handsfree devices must be installed by qualified personnel. Faulty installation or operation can constitute a safety hazard.



IMPORTANT!

Cellular terminals or mobiles operate using radio signals and cellular networks cannot be guaranteed to connect in all conditions. Therefore, you should never rely solely upon any wireless device for essential communications, for example emergency calls.

Remember, in order to make or receive calls, the cellular terminal or mobile must be switched on and in a service area with adequate cellular signal strength.

Some networks do not allow for emergency calls if certain network services or phone features are in use (e.g. lock functions, fixed dialling etc.). You may need to deactivate those features before you can make an emergency call.

Some networks require that a valid SIM card be properly inserted in the cellular terminal or mobile.



If a power supply unit is used to supply the device, it must meet the demands placed on SELV circuits in accordance with EN60950. The maximum permissible connection length between the device and the supply source should not exceed 3m.



According to the guidelines for human exposure to radio frequency energy, an antenna connected to the FME jack of the device should be placed at least 20cm away from human bodies.

1.4 Terms and abbreviations

Table 1: Terms and abbreviations

Abbreviation	Description
ADC	Analog-to-Digital Converter
ARP	Antenna Reference Point
ASIC	Application Specific Integrated Circuit
ATC	AT Cellular
BTS	Base Transceiver Station
CB	Cell Broadcast
CODEC	Coder-Decoder
CPU	Central Processing Unit
DCE	Data Circuit terminating Equipment
DSB	Development Support Box
DSP	Digital Signal Processor
DSR	Data Set Ready
DTR	Data Terminal Ready
EFR	Enhanced Full Rate
EGSM	Enhanced GSM
EMC	Electromagnetic Compatibility
ESD	Electrostatic Discharge
ETS	European Telecommunication Standard
FDMA	Frequency Division Multiple Access
FR	Full rate
G.C.F.	GSM Conformity Forum
GSM	Global Standard for Mobile Communication
HF	Hands-free
HR	Half rate
HW	Hardware
IC	Integrated Circuit
IF	Intermediate Frequency
IMEI	International Mobile Equipment Identifier
I/O	Input/ Output
IGT	Ignition
ISO	International Standards Organization
ITU	International Telecommunications Union
kbits	kbits per second

Abbreviation	Description
Li-Ion	Lithium-Ion
LVD	Low voltage Directive
Mbps	Mbits per second
MMI	Machine Machine Interface
MO	Mobile Originated
MS	Mobile Station
MT	Mobile Terminated
NC	Not Connected
NTC	Negative Temperature Coefficient
PA	Power Amplifier
PCB	Printed Circuit Board
PCM	Pulse Code Modulation
PCS	Personal Communication System
PD	Power Down
PDU	Protocol Data Unit
R&TTE	Radio and Telecommunication Terminal Equipment
RAM	Random Access Memory
RF	Radio frequency
RI	Ring Indication
ROM	Read Only Memory
RX	Receive direction
SIM	Subscriber Identification Module
SMS	Short Message Service
SRAM	Static Random Access Memory
SW	Software
TDD	Time Division Duplex
TDMA	Time Division Multiple Access
TX	Transmit direction
UART	Universal Asynchronous Receiver and Transmitter
VAD	Voice Activity Detection
ZIF	Zero Insertion Force

2 Key features of MC35i Terminal

Table 2: Key features

Feature	Implementation
Transmission	Voice, Data, SMS, Fax
Power supply	Single supply voltage 8V to 30V
GSM class	Small MS
Frequency bands	<ul style="list-style-type: none"> Dual Band E-GSM 900 and GSM 1800 Compliant to GSM Phase 2/2+
Transmit power	<ul style="list-style-type: none"> Class 4 (2W) for EGSM900 Class 1 (1W) for GSM1800
GPRS connectivity	GPRS multi-slot class 8 GPRS mobile station class B
SIM card reader	Internal
External antenna	Connected via antenna FME connector
Speech codec	Triple rate codec: <ul style="list-style-type: none"> Half Rate (ETS 06.20) Full Rate (ETS 06.10) Enhanced Full Rate (ETS 06.50 / 06.60 / 06.80)
SMS	MT, MO, CB, Text and PDU mode
DATA	<p><i>GPRS:</i></p> <ul style="list-style-type: none"> GPRS data downlink transfer: max. 85.6 kbps (see Table 3) GPRS data uplink transfer: max. 21.4 kbps (see Table 3) Coding scheme: CS-1, CS-2, CS-3 and CS-4 MC35i Terminal supports the two protocols PAP (Password Authentication Protocol) and CHAP (Challenge Handshake Authentication Protocol) commonly used for PPP connections. Support of Packet Switched Broadcast Control Channel (PBCCH) allows you to benefit from enhanced GPRS performance when offered by the network operators. <p><i>CSD:</i></p> <ul style="list-style-type: none"> CSD transmission rates: 2.4, 4.8, 9.6, 14.4 kbps, non-transparent, V.110 Unstructured Supplementary Services Data (USSD) support
FAX	Group 3: Class 1, Class 2
Audio interface	Analog (Microphone, Earpiece)
Serial interface	<ul style="list-style-type: none"> RS-232 interface, bi-directional bus for AT commands and data Multiplex ability according to GSM 07.10 Multiplexer protocol Baud rates from 300bps to 115.200bps Autobauding supports: 1.200, 2.400, 4.800, 9.600, 19.200, 38.400, 57.600 and 115.200bps
Supported SIM card	3V
Phonebook management	Supported phonebook types: SM, FD, LD, MC, RC, ON, ME

Feature	Implementation
Reset of MC35i Terminal	Reset via AT command or Power Down Signal
Firmware upgrade	Upgradable via serial interface or SIM interface.
Real time clock	Implemented (clock frequency 32.768kHz)
Environmental	Temperature: <ul style="list-style-type: none"> • Normal operation: -20°C to +55°C • Humidity: max. 80 % relative humidity
Size	65x74x33 mm (approx.)
Weight	130g

Table 3: Coding schemes and maximum net data rates over air interface

Coding scheme	1 Timeslot	2 Timeslots	4 Timeslots
CS-1:	9.05 kbps	18.1 kbps	36.2 kbps
CS-2:	13.4 kbps	26.8 kbps	53.6 kbps
CS-3:	15.6 kbps	31.2 kbps	62.4 kbps
CS-4:	21.4 kbps	42.8 kbps	85.6 kbps

Please note that the values stated above are maximum ratings which, in practice, are influenced by a great variety of factors, primarily, for example, traffic variations and network coverage.

3 Interface description

3.1 Overview

MC35i Terminal provides the following connectors for power supply, interfacing and antenna:

- 6-pole Western plug (female) for power supply, ignition, power down signal
- 4-pole Western plug (female) for audio accessory, such as a handset
- 9-pole (female) SUB-D plug for RS-232 serial interface
- FME Jack (male) for antenna (Radio Interface)
- SIM card holder

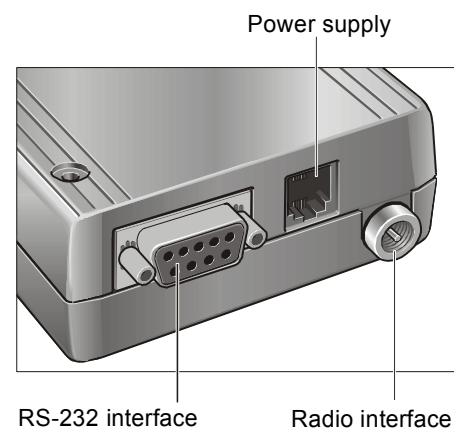
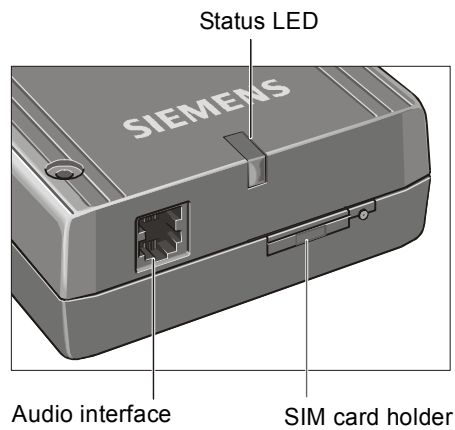

3.2 Block diagram of a GSM application

Figure 1 shows a block diagram of a sample configuration that incorporates a MC35i Terminal and typical accessories.

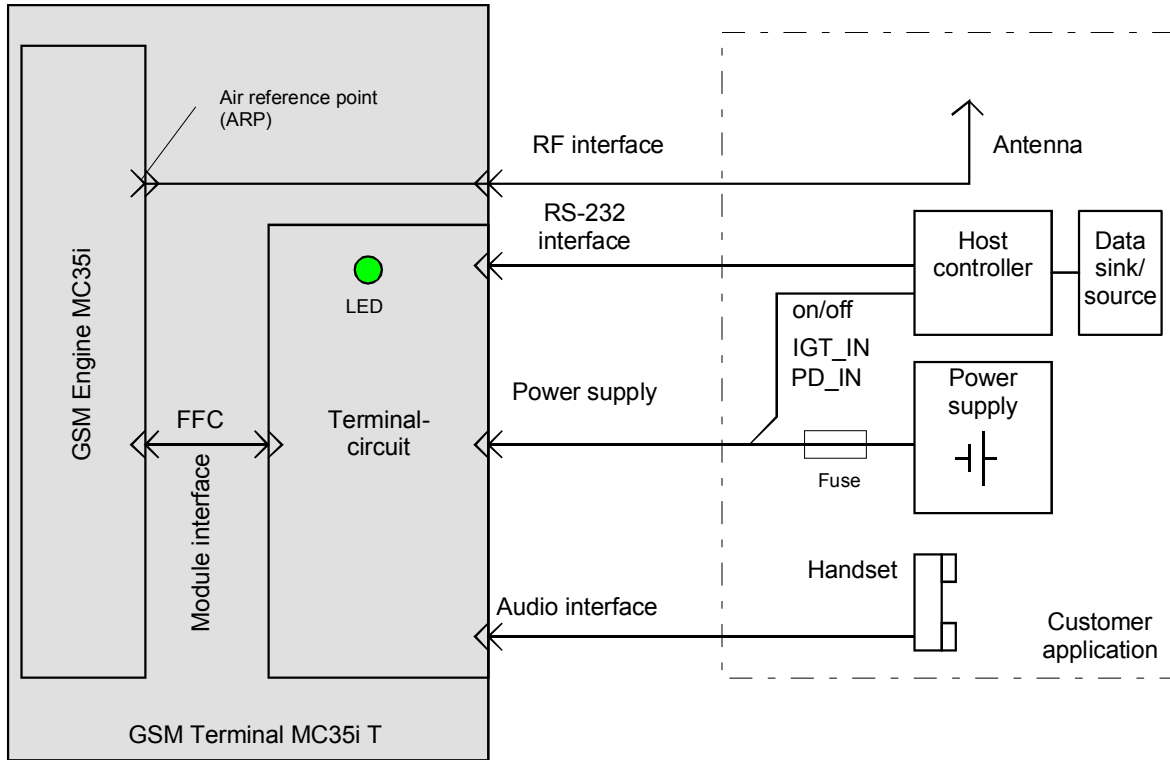

Figure 1: Block diagram of a MC35i Terminal application (example)

3.3 The MC35i GSM /GPRS engine

The MC35i GSM / GPRS engine is a major functional component of the MC35i Terminal that handles all the processing for audio, signal and data within a GSM / GPRS cellular device. Internal software runs the application interface and the whole GSM and GPRS protocol stack. A UART forms the interface to the Terminal Circuit.

Designed to easily provide radio connection for voice and data transmissions it integrates seamlessly with a wide range of GSM / GPRS application platforms and is ideally suited to design and set up innovative cellular solutions with minimum effort.

MC35i Terminal supports GPRS multislots class 8 (4 Rx, 1 Tx time slot) and GPRS coding schemes CS-1, CS-2, CS-3 and CS-4. It operates in the frequency bands GSM 900 MHz and GSM 1800 MHz.

A GSM baseband processor contains all analog and digital functionality of a cellular radio. Designed to meet the increasing demands of the GSM/PCS/GPRS cellular subscriber market, it supports FR, HR and EFR speech and channel coding without the need for external hardware.

The RF part of the GSM engine MC35i is based on a highly integrated single transceiver chip solution.

The internal antenna cable connects to the connector type GSC from Murata with a 50Ω impedance. This GSC connector is the ARP (Antenna Reference Point) for type approval measurements as well as for electrical characteristics.

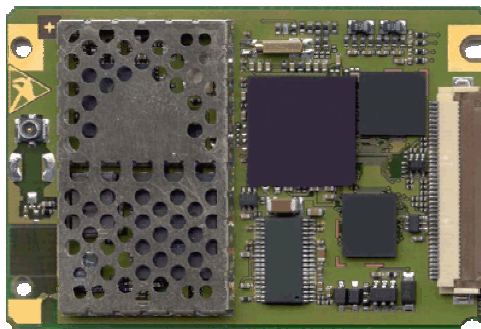

Figure 2: MC35i GSM engine

3.4 Operating modes

The table below briefly summarizes the various operating modes referred to in the following chapters.

Table 4: Overview of operating modes

Mode	Function	
Normal operation	SLEEP	<p>Various power saving modes set by AT+CFUN command.</p> <p>Software is active to minimum extent. If the Terminal was registered to the GSM network in IDLE mode, it remains, in SLEEP mode, registered and pageable from the BTS.</p> <p>Power saving can be chosen at different levels. The NON-CYCLIC SLEEP mode (AT+CFUN=0) disables the AT interface. The CYCLIC SLEEP mode AT+CFUN=5, 6, 7 and 8 alternately activate and deactivate the AT interface to allow permanent access to all AT commands.</p>
	GSM IDLE	Software is active. Once registered to the GSM network, paging with BTS is carried out. The Terminal is ready to send and receive.
	GSM TALK	Connection between two subscribers is in progress. Power consumption depends on network coverage individual settings, such as DTX off/on, FR/EFR/HR, hopping sequences, antenna.
	GPRS IDLE	Module is ready for GPRS data transfer, but no data is currently sent or received. Power consumption depends on network settings and GPRS configuration (e.g. DRX settings)
	GPRS DATA	GPRS data transfer in progress. Power consumption depends on network settings (e.g. power control level), uplink / downlink data rates and GPRS configuration (e.g. used multislot settings).
Power Down	Operating voltage applied. Only a voltage regulator in the Power Supply ASIC is active for powering the RTC. Software is not active. The RS-232 interface is not accessible.	

3.5 Terminal circuit

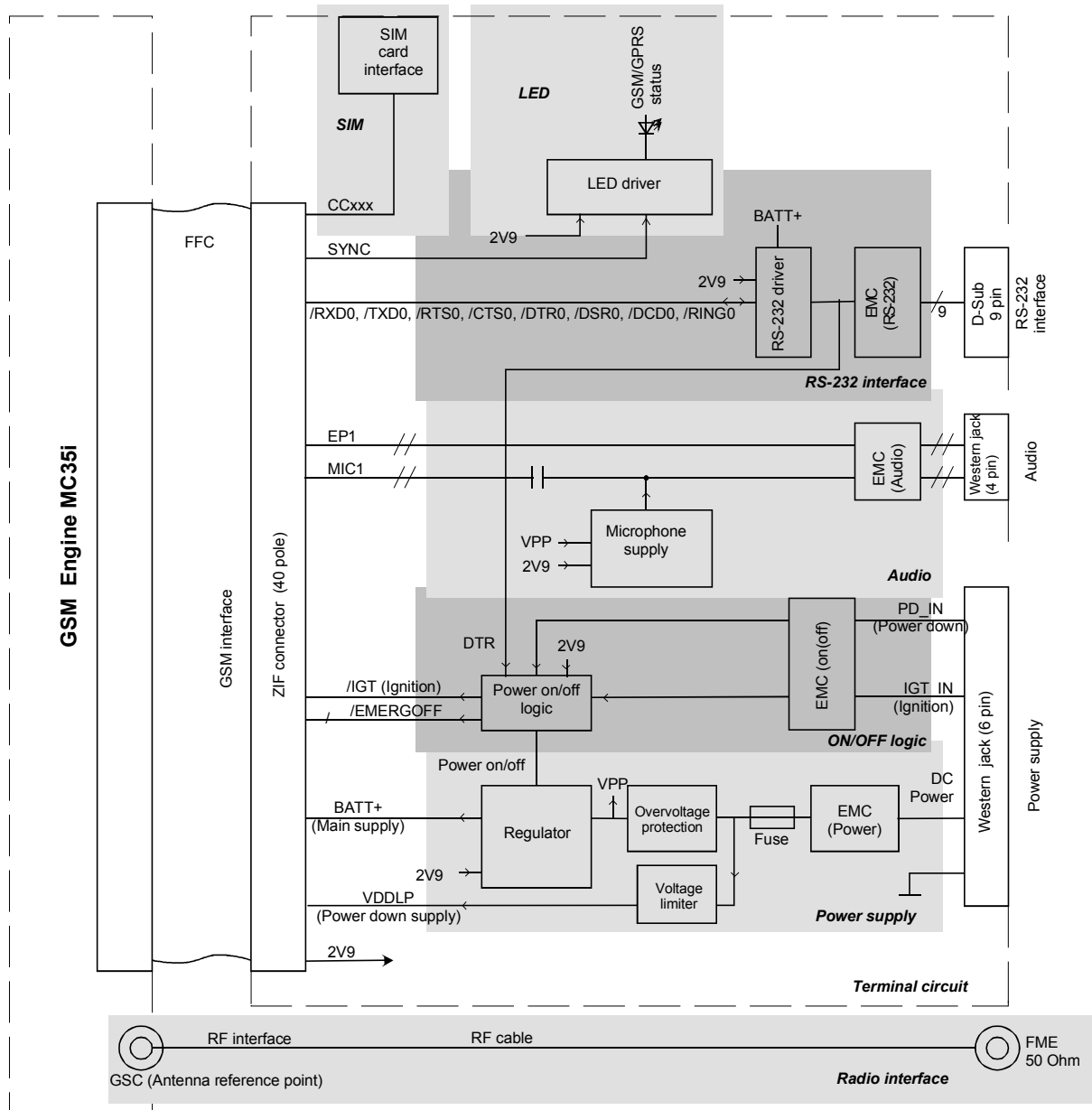

Figure 3: MC35i Terminal circuit block diagram

3.5.1 Power supply and On/Off control

The power supply of the MC35i Terminal has to be a single voltage source of $V_{PLUS}=8V\dots30V$ providing a peak current (pulsed 577ms at $T=4.615ms$) of about 1.2A at 12V during the active transmission. The uplink burst causes strong ripple (drop) on the power lines. The drop voltage should not exceed 1V, but the absolute minimum voltage during drops must be $>7.6V$. The terminal is protected from supply voltage reversal and overvoltage. An internal fuse is not removable and intended for electrical safety according to EN60950. To protect the device from high voltages ($>30V$) an additional 1.25A quick-break fuse on Pin 1 of the 6-pole Western plug shall be used.

In case you wish to use MC35i Terminal with power packs and batteries observe the EN60950 guidelines.

A switching regulator regulates the input voltage for the internal supply. In POWER DOWN mode the switching regulator is turned off by the On/Off logic.

A separate voltage regulator supplies the real time clock in the GSM engine.

When power fails for $>1ms$, MC35i Terminal resets or switches off and for $>7s$ the RTC will be reset.

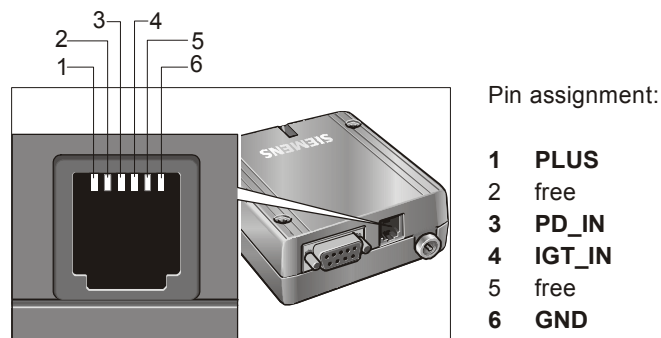

Figure 4: Female 6-pole Western plug for power supply, ignition, power down

Mains adapter:

It is recommended to use the adapter of the type approval reference configuration. Ordering information can be found in Chapter 7. This 12V mains adapter comes with a 6-pole Western plug and features an internal connection between IGT_IN pin and PLUS pin for auto ignition (power up).

Table 5: Female 6-pole Western plug for power supply, ignition, power down

Pin	Signal Name	Use	Parameters
1	PLUS	Power supply	8V – 30V DC, max. 33V for 1 min
2	free	---	---
3	PD_IN	Signal for power down mode	$U_{IH} \geq 5V$ for $t > 3.5s$ to switch the terminal off, $U_{IL} < 2V$ for normal operation
4	IGT_IN	Ignition ^{*)}	$U_{IH} \geq 5V$ Ignition $\geq 5V$ for more than 200ms switches the terminal on
5	free	---	---
6	GND	Ground	0V

^{*)} The ignition is activated only by a rising edge. The rise time is $< 20ms$.
The IGT_IN signal switches the terminal on (it changes from power down state to the net searching state).

Note :

- Power off exception handling: In the event of software hang-ups etc. the MC35i Terminal can be switched off by applying a voltage $> 5V$ to pin 3 (PD_IN) for more than 3.5s. To switch on again you have two options: Activate the ignition pin (IGT_IN pin 4) or switch on the RS-232 DTR line, during /PD_IN not active (pin 3 voltage $< 2V$). The /PD_IN signal switches the terminal off. All internal supply voltages are off, except for the power down voltage, which still feeds the real-time clock (RTC). See Chapter 3.5.2 for use of the RTC.
- For all other operating modes the /PD_IN signal must be low ($< 2V$).
- When the MC35i Terminal is switched off or enters the Power Down mode, e.g. after you have issued the AT^SMSO command or activated the /PD_IN signal, all RS-232 interface lines are undefined during internal power shutdown process. This may cause undefined characters which can be ignored.
- In order to properly shut down the MC35i Terminal be sure to wait 10s after sending AT^SMSO before switching off the power supply at pin PLUS. This time is needed for the module to safely log off from the network and finish saving to the internal memory.

Caution: *Use the /PD_IN pin only when, due to serious problems, the software is not responding for more than 5 seconds. Pulling the /PD pin causes the loss of all information stored in the volatile memory since power is cut off immediately. Therefore, this procedure is intended only for use in case of emergency, e.g. if MC35i Terminal fails to shut down properly.*

3.5.1.1 Maximum number of turn/on & turn/off cycles

Each time the MC35i Terminal is shut down, data will be written from the volatile memory to flash memory. The guaranteed maximum number of write cycles is limited to 100.000.

3.5.2 RTC

The internal Real Time Clock (RTC) of MC35i Terminal is supplied from a dedicated voltage regulator which is also active when MC35i Terminal is in POWER DOWN mode. The RTC retains the time and is necessary for the reminder function (even if MC35i Terminal is disconnected from power supply, see Table 12 for details). For example, you can set an alarm by using the AT+CALA command. Once the alarm time is reached, a reminder URC will be returned. See [1] for detailed instructions on use of the command AT+CALA. Please note that the alarm mode described in [1] is not intended for MC35i Terminal.

It is not recommended to power down MC35i Terminal after setting an alarm, because an alarm call does not wake up MC35i Terminal from POWER DOWN mode.

3.6 Upgrading MC35i Terminal firmware

The MC35i Terminal firmware can be easily upgraded to the latest firmware releases.

The terminal offers two different solutions for updating firmware. In most cases, you can update the firmware via the RS-232 interface. In case you wish to use the SIM interface you will need to purchase a special adapter named BB35 Bootbox. Ordering information can be found in Chapter 7.

The latest software releases can be obtained from your local Siemens dealer or visit the Siemens homepage.

3.6.1 RS-232 interface

Via RS-232 interface, the host controller controls the MC35i Terminal and transports data.

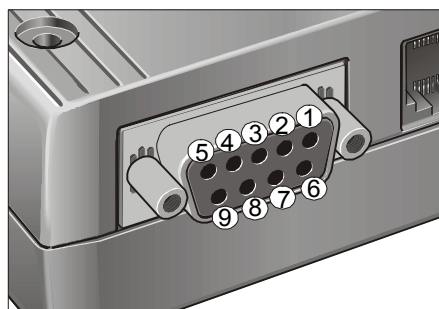

Figure 5: Pin assignment RS-232 (D-Sub 9-pole female)

EMC immunity complies with the vehicular environment requirements according to EN 301 489-7.

Table 6: 9-pole D-Sub (female) RS-232

Pin no.	Signal name	I/O	Function
1	/DCD	O	Data Carrier Detected
2	/RXD	O	Receive Data
3	/TXD	I	Transmit Data
4	/DTR	I	Data Terminal Ready Attention: The ignition of MC35i Terminal is activated via a rising edge of high potential (+5 ... +15 V)
5	GND	-	Ground
6	/DSR	O	Data Set Ready
7	/RTS	I	Request To Send
8	/CTS	O	Clear To Send
9	/RI	O	Ring Indication

The current of all signals is limited by serial resistors:

Outputs: 470 Ohm

Inputs: 1kOhm

MC35i Terminal is designed for use as a DCE. Based on the conventions for DCE-DTE connections it communicates with the customer application (DTE) using the following signals:

- Port TxD @ application sends data to TXD of MC35i Terminal
- Port RxD @ application receives data from RXD of MC35i Terminal

The RS-232 interface is implemented as a serial asynchronous transmitter and receiver conforming to ITU-T V.24 Interchange Circuits DCE. It is configured for 8 data bits, no parity and 1 stop bit, and can be operated at bit rates from 300bps to 115kbps. Autobauding supports bit rates from 4.8kbps to 115kbps. Hardware handshake using the /RTS and /CTS signals and XON/XOFF software flow control are supported.

In addition, the modem control signals /DTR^{*)}, /DSR, /DCD and /RING are available. The modem control signal RING (Ring Indication) can be used to indicate, to the cellular device application, that a call or Unsolicited Result Code (URC) is received. There are different modes of operation, which can be set with AT commands.

*) **The /DTR signal will only be polled once per second from the internal firmware of MC35i.**

3.6.2 Audio interface

The audio interface provides an analog input for a microphone and an analog output for an earpiece.

- The microphone input and the earpiece output are balanced.
- For electret microphones a supply source is implemented.
- The microphone supply characteristics are optimized for the recommended Votronic handset. For ordering Information see Chapter 7.
- This handset has been used as the reference handset for type approval. An extra approval must be obtained for integrating other handsets or amplifiers.

The amplification of sending direction, receiving direction and sidetone depend on the current audio mode.

EMC immunity complies with the vehicular environment requirements according to EN 301 489-7.

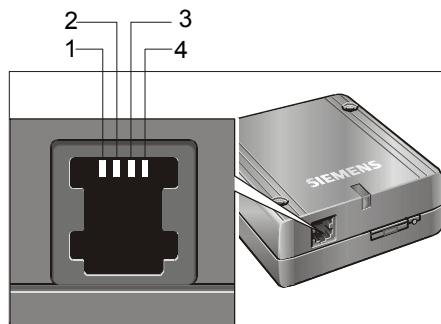

Pin assignment:

- 1 MICN (Microphone -)
- 2 EPN (Earpiece)
- 3 EPP (Earpiece)
- 4 MIPC (Microphone +)

Figure 6: Audio Western plug (4-pole female)

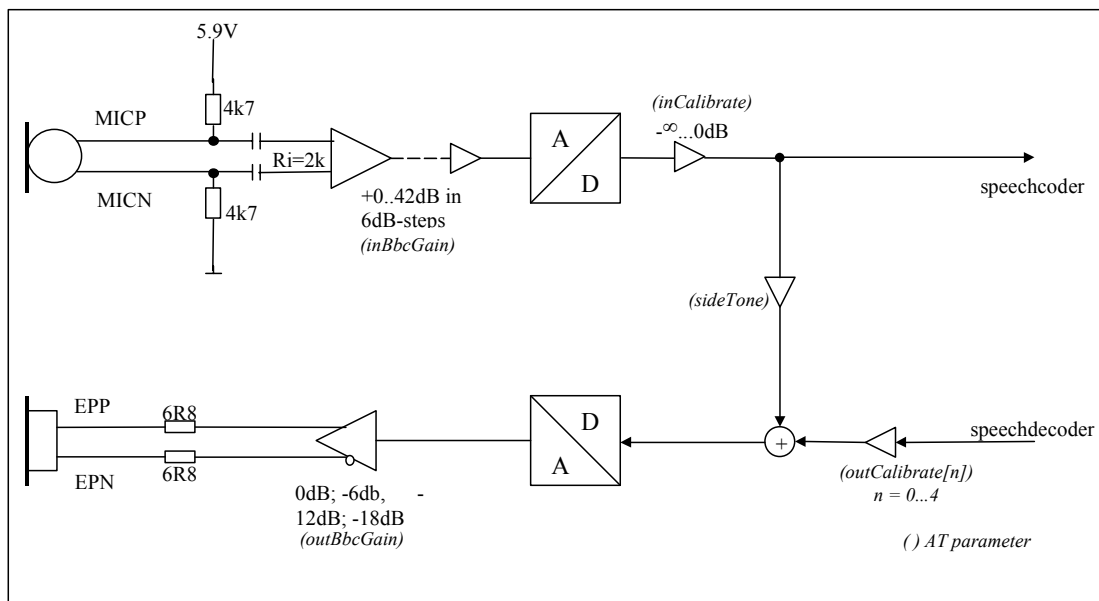

Figure 7: Audio block diagram

The audio interface can be configured by AT commands. Please note that the 2nd audio interface mentioned in [1] is not connected. Audio modes 2, 3 and 6 can be selected by setting AT^SAIC=2,1,1, for further details refer to [1].

The electrical characteristics of the voiceband part vary with the audio mode. To suit several types of audio equipment, three audio modes given by default can be selected by the AT command AT^SNFS, see [1]. In audio mode 4 and 5, the gain in the microphone, earpiece and the sidetone path can be adjusted from the cellular device application (different volume steps can be selected by AT commands). See *Table 16: AT adjustable parameters* for the characteristics of the audio modes.

Table 7: Audio modes

Mode No AT^SNFS=	1	4	5
Name	Default Handset	User Handset	Plain Codec 1
Purpose	Recommended handset (see chapter 6)	User provided handset	Direct access to speech coder
Gains programmable via AT command	NO	YES	YES
Sidetone	YES	YES	YES
Volume control	NO	YES	YES
Limiter (receive)	YES	YES	NO
Echo control (send)	Suppression	Suppression	NO
MIC input signal for 0dBm0 @ 1024 Hz (at default gain settings)	12.5 mV	12.5 mV	315 mV
Earpiece output signal in mV eff. @ 0dBm0, 1024 Hz, no load (at default gain settings); @ 3.14 dBm0	275 mV	275 mV default @ max volume	880 mV 3.7 Vpp
Sidetone gain (at default settings)	27.7 dB	27.7 dB	-∞ dB

Speech processing:

The voiceband filter includes a digital interpolation low-pass filter for received voiceband signals with digital noise shaping and a digital decimation low-pass filter for voiceband signals to be transmitted.

After voiceband (interpolation) filtering the resulting 2Mbit/s data stream is digital-to-analog converted and amplified by a programmable gain stage in the voiceband processing part. The output signal can directly be connected to the earpiece of the GSM cellular device or to an external handset earpiece (via I/O connector). In the opposite direction the input signal from the microphone is first amplified by a programmable amplifier. After analog-to-digital conversion a 2Mbit/s data stream is generated and voiceband (decimation) filtering is performed.

The resulting speech samples from the voiceband filters are handled by the DSP of the baseband controller to calculate e.g. amplifications, sidetone, echo cancellation or noise suppression.

Full rate, half rate and enhanced full rate, speech and channel encoding including voice activity detection (VAD) and discontinuous transmission (DTX) and digital GMSK modulation are also performed on the GSM baseband processor.

Note: With regard to acoustic shock, the cellular application must be designed to avoid sending false AT commands that might increase the amplification, e.g. for a high sensitive earpiece.

3.6.3 Radio interface

An internal antenna cable adapts the antenna reference point (antenna connector type GSC from Murata) to the FME (male) connector. The position of the antenna reference point can be seen in Figure 1.

Inside the MC35i module a 27nH inductor to ground provides additional ESD protection to the antenna connector. For details see Figure 8.

To protect the inductor from damage no DC voltage must be applied to the antenna circuit.

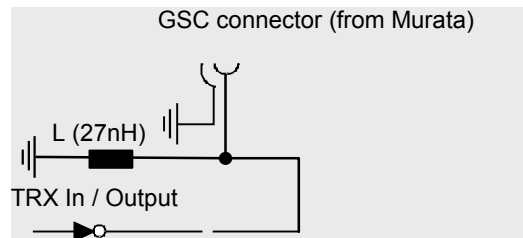

Figure 8: Antenna connector circuit on MC35i module

- Cable loss of internal cable
 - <0.4dB @ 900MHz
 - <0.6dB @ 1800MHz
- The system impedance is 50Ω.
- In every case, for good RF performance the return loss of the customer application should be better than 10dB (VSWR < 2).
- MC35i Terminal withstands a total mismatch at this connector when transmitting with power control level for maximum RF Power.

EMC immunity complies with the vehicular environment requirements according to EN 301 489-7.

For the application it is recommended to use an antenna with the following FME (female) connector:

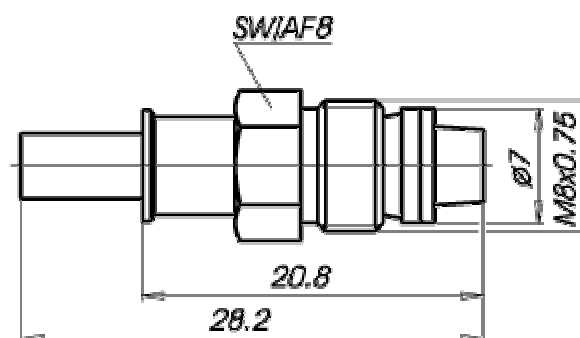
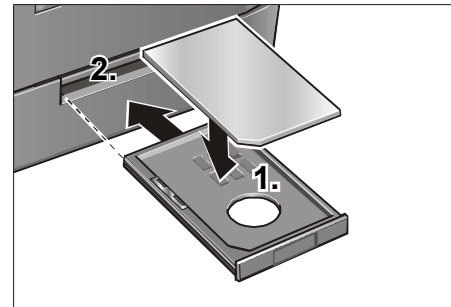

Figure 9: Recommended antenna connector

3.6.4 SIM interface

The SIM interface is intended for 3V SIM cards in accordance with GSM 11.12 Phase 2. The card holder is a five wire interface according to GSM 11.11. A sixth pin has been added to detect whether or not a SIM card is inserted.

All signals of the SIM interface are protected from electrostatic discharge with spark gaps to GND and clamp diodes to 2.9V and GND.



Removing and inserting the SIM card during operation requires the software to be reinitialized. Therefore, after reinserting the SIM card it is necessary to restart MC35i Terminal.

Note: No guarantee can be given, nor any liability accepted, if loss of data is encountered after removing the SIM card during operation.

Also, no guarantee can be given for properly initializing any SIM card that the user inserts after having removed a SIM card during operation. In this case, the application must restart MC35i Terminal.

3.6.5 Status LED

A green LED displays the operating status of the terminal:

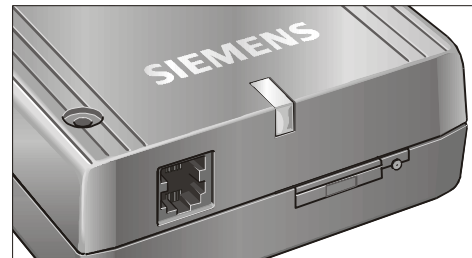

Table 8: Coding of the green status LED

Operating status	LED
Power Down	off
Not registered to the net (missing SIM, PIN, net)	fast blinking
Standby (registered to the net)	slow flash (75ms On / 3s Off)
Sleep mode (Power save mode, registered to the net)	off
Talk mode, GPRS data	on

4 Mechanical characteristics and mounting advice

Table 9: Mechanical characteristics

Weight	130 g
Dimensions (max) LxWxH =	65x74x33mm
Temperature range	-20°C to +55 °C
Protection class	IP40 (Avoid exposing MC35i Terminal to liquid or moisture, for example do not use it in a shower or bath.)
Mechanical vibrations Amplitude	7.5 mm at 5-200 Hz sinus
Max. pulse acceleration	30g pulse with 18 ms duration time
Air humidity	5...80% (non condensing)
Class of flammability	UL94 HB
Casing material	PC/ABS Cycloy 1200 HF grey 96444

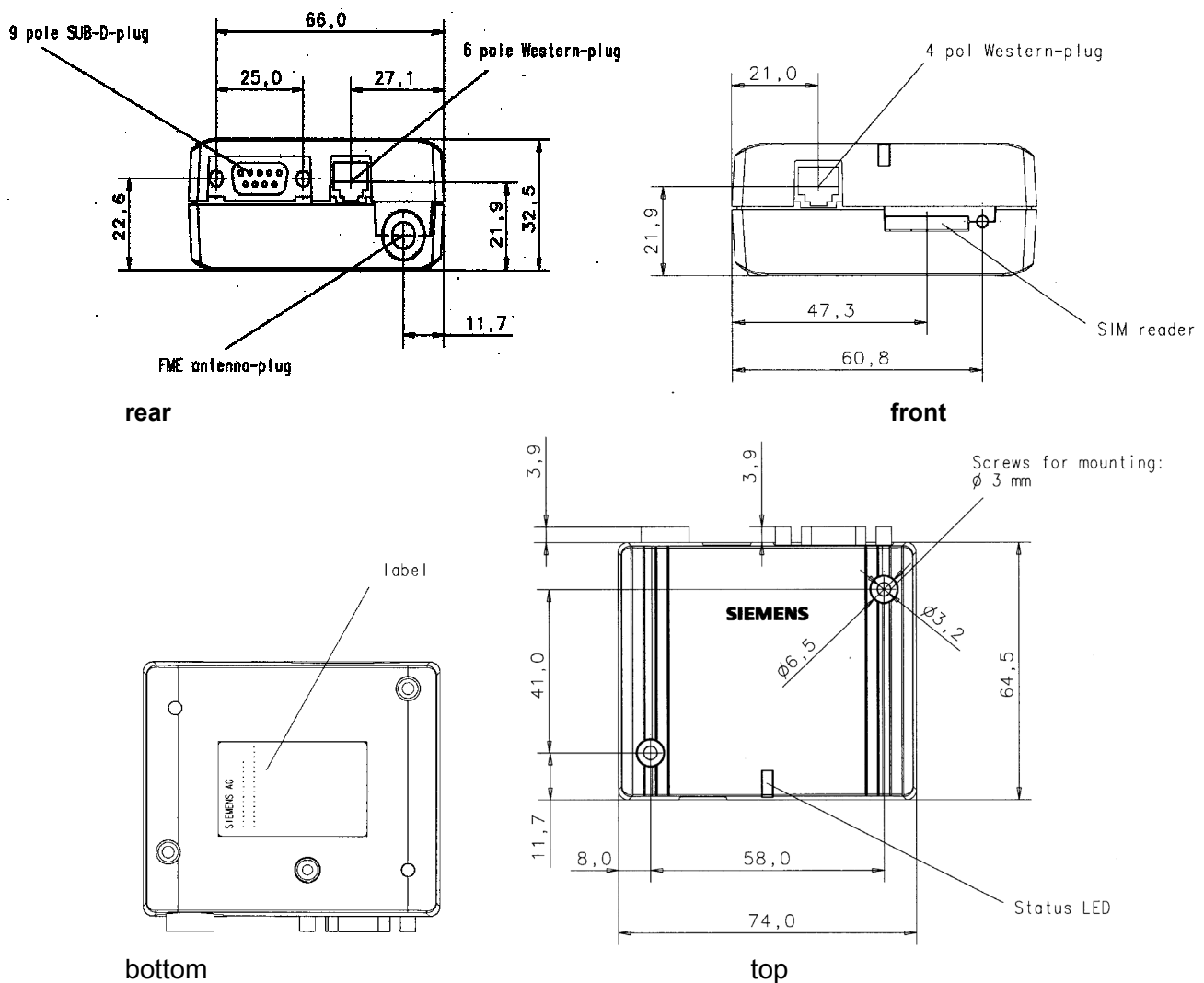

Figure 10: Design drawing

4.1 Attaching the terminal

The MC35i Terminal can be attached e.g. to a 35mm top-hat rail installation using two M3 x 50mm screws and an additional fixture element, see Figure 12. In case you wish to order the recommended mounting kit, please refer to Chapter 7 for detailed information.

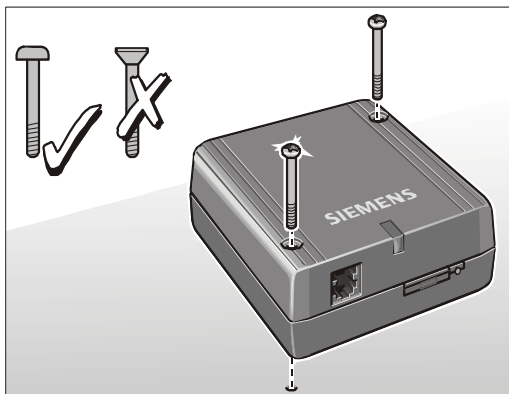

Figure 11: Recommended screws

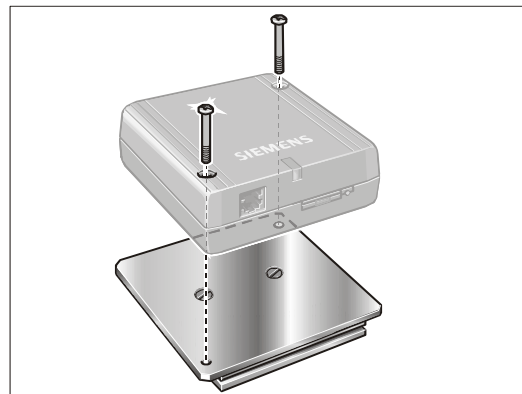

Figure 12: Attaching MC35i Terminal onto a top-hat rail

5 Electrical and environmental characteristics

Table 10: Absolute maximum ratings

Parameter	Port / Description	Min.	Max.	Unit
Supply voltage	PLUS	-50	30	V
Oversvoltage	PLUS / for 1min		33	V
Input voltage for on/off Control lines	/IGT_IN, /PD_IN	-5	30	V
RS-232 input voltage range	/TXD, /DTR, /RTS	-30	+30	V
	/RXD, /CTS, /DSR, /DCD, /RING	-0.3	+5.3	V
Microphone input line voltage	MICP, MICN	-0.3	+10	V
Earpiece input voltage	EPP, EPN	-0.3	+3.3	V
Immunity against discharge of static electricity	all connectors (lines)	-8	+8	kV
Protection Class	IP40 (avoid exposing MC35i Terminal to liquid or moisture, for example do not use it in a shower or bath)		IP 40	
Mechanical vibrations amplitude	@ 5-200Hz		7.5	mm
Mechanical pulse-acceleration	@ 18 ms duration		30	g

Table 11: Operating conditions

Parameter	Min	Typ	Max	Unit
Ambient temperature	-20	25	55	°C
Supply voltage PLUS measured at (6-pole) western jack plug (1 to 6)	7.6 lowest voltage (minimum peak) incl. all ripple and drops	12	30	V

Table 12: Characteristics power supply

Parameter	Description	Conditions	Min	Typ	Max	Unit
V _{PLUS}	Allowed voltage ripple (peak-peak), drop during transmit burst peak current	Talk Mode, power control level for P _{out} max ¹⁾			1	V
I _{PLUS} ²⁾	Average supply current (average time 3 min.)	Power Down mode	@8V	480	550	μA
			@12V	700	800	
			@30V	1750	1850	
		SLEEP mode (GSM/GPRS)	@8V	45		mA
			@12V	30		
			@30V	17		
		NET Searching mode (NO NET)	@8V	70		mA
			@12V	50		
			@30V	30		
		IDLE mode (GSM/GPRS)	@8V	60		mA
			@12V	45		
			@30V	25		
		GSM TALK mode	@8V	270	560	mA
			@12V	170	330	
			@30V	72	125	
GPRS DATA mode(1 Tx, 4 RX)	@8V	290	570	mA		
	@12V	180	330			
	@30V	77	125			
Peak supply current (during 577μs transmission slot every 4.6ms)	Power control level for P _{out} max	@12V	1,7	3.2	A	
		@30V	1.2	2.4		
		@30V	0.7	1.2		
t _{PLUS-Fail}	Allowed powerfail time without terminal reset or power down	After this time the Terminal will be reset or switched off			1	ms
	Allowed powerfail time without RTC (real time clock) reset	After this time the RTC will be reset			7	s
t _{R_PLUS}	Allowed rise time of V _{PLUS}	0% to 100%			20	ms
LE _{Cable}	Length of supply cable				3	m

¹⁾ Lowest voltage (minimum peak) incl. all ripple and drops >7.6V including voltage drop, ripple and spikes, measured at western jack (6-pole) pin (1 to 6)

²⁾ Typical values measured with antenna impedance = 50 Ohm (return loss >20dB)
Maximum values measured with mismatched antenna

Table 13: Characteristics (requirements) On/Off control lines

Parameter	Description	Conditions	Min	Typ	Max	Unit
V _{high}	Input voltage	active high	5			V
V _{low}	/IGT_IN, /PD_IN, /DTR				2	V
R _{IN}	Input resistance of /IGT_IN, /PD_IN		47			kOhm
R _{IN}	Input resistance of /DTR		4	6	8	kOhm
t _{D_IGT}	Duration of active high /IGT_IN, /DTR		200			ms
t _{D_PD}	Duration of active high /PD_IN		3.5			s
t _{R_IGT}	Rise time /IGT_IN for power up	0% to 100%			20	ms
t _{R_RTS}	Rise time /DTR for power up	0% to 100%			20	ms
t _{D_passive}	Duration passive (low) of /IGT_IN, /DTR before restart	after power down	1			s

Table 14: Characteristics (requirements) RS-232 interface

Parameter	Description	Conditions	Min	Typ	Max	Unit
V _{OUT}	Transmitter Output Voltage for /RXD, /CTS, /DSR, /DCD, /RING	@ 5kOhm load	±5	±6	±7	V
R _{OUT}	Transmitter Output Resistance /RXD, /CTS, /DSR, /DCD, /RING				770	Ohm
R _{IN}	Receiver Input Resistance /TXD, /RTS, /DTR		4	6	8	kOhm
V _{RIHYS}	Input Hysteresis		0.2	0.5	1	V
V _{llow}	Input Threshold Low		1.0	1.8		V
V _{lhigh}	Input Threshold High			2.4	3	V
Baudrate		Autobauding	4.8		115	kbps
		Fixed range	0.300		115	kbps
LE _{Cable}	Length of RS-232 cable			1.8	2	m

Table 15: Characteristics (requirements) audio interface

Parameter		Min.	Typ.	Max.	Unit
Microphone MICP, MICN	DC (no load) at MICP	5.6	5.9	6.2	V
	DC at MICP in POWER DOWN		0		V
	DC (no load) at MICN		0		V
	DC Resistance differential MICN, MICP (balanced)	9.3	9.4	9.5	kOhm
	Impedance Z_i (balanced)	1.4	1.5	1.7	kOhm
	Input level $U_{i_{max}}$			1.03	V_{PP}
	Gain range 6 dB steps	0		42	dB
	Frequency Range	300		3400	Hz
Earpiece EPP, EPN	fine scaling by DSP (inCalibrate)	$-\infty$		0	dB
	Impedance (audio not active)		30		kOhm
	Impedance (balanced)		15		Ohm
	AC output level U_o <i>Gain</i> = 0dB @ 3.14 dBm0 no load audio mode = 5, outBbcGain = 0, outCalibrate = 32767	3.3	3.7	4.07	V_{PP}
	Gain range	-18		0	dB
	Gain accuracy			0.8	dB
	Frequency area	300		3400	Hz
	DC Offset (balanced)			100	mV
	Attenuation distortion for 300...3900Hz			1	dB
	Out-of-band discrimination	60			dB
LE_{Audio}	Length of Audio (Handset) cable			3	m

Unless otherwise stated, all specified values are valid for gain setting (*gs*) 0dB and 1kHz test signal.

gs = 0dB means audio mode = 5 for EPP to EPN, inBbcGain= 0, inCalibrate = 32767, outBbcGain = 0, OutCalibrate = 16384, sideTone = 0.

Audio Modes:

The electrical characteristics of the voiceband part depend on the current audio mode selected by the AT command AT^SNFS. See Table 7: Audio modes.

The audio modes 4 and 5 can be adjusted by parameters. Each audio mode is assigned a separate parameter set.

Table 16: AT adjustable parameters

Parameter	Influence to	Range	Gain range	Calculation
inBbcGain	MICP/MICN analogue amplifier gain of baseband controller before ADC	0...7	0...42dB	6dB steps
inCalibrate	digital attenuation of input signal after ADC	0...32767	-∞...0dB	$20 * \log(\text{inCalibrate}/32768)$
outBbcGain	EPP/EPN analogue output gain of baseband controller after DAC	0...3	0...-18dB	6dB steps
outCalibrate[n] n = 0...4	digital attenuation of output signal after speech decoder, before summation of sidetone and DAC present for each volume step[n]	0...32767	-∞...+6dB	$20 * \log(2 * \text{outCalibrate}[n]/32768)$
sideTone	digital attenuation of sidetone is corrected internally by outBbcGain to obtain a constant sidetone independently to output volume	0...32767	-∞...0dB	$20 * \log(\text{sideTone}/32768)$

Note: The parameters inCalibrate, outCalibrate and sideTone accept also values from 32768 to 65535. These values are internally truncated to 32767.

Table 17: Air interface

Parameter		Min	Typ	Max	Unit
Frequency range Uplink (MS → BTS)	E-GSM 900	880		915	MHz
	GSM 1800	1710		1785	MHz
Frequency range Downlink (BTS → MS)	E-GSM 900	925		960	MHz
	GSM 1800	1805		1880	MHz
RF power @ ARP at 50Ω load	E-GSM 900	30.5	33	35	dBm
	GSM 1800	27.5	30	32	dBm
Number of carriers	E-GSM 900		174		
	GSM 1800		374		
Duplex spacing	E-GSM 900		45		MHz
	GSM 1800		95		MHz
Carrier spacing			200		kHz
Multiplex, Duplex	TDMA / FDMA, FDD				
Time slots per TDMA frame			8		
Time slots usable RX / TX			1 / 1		
Frame duration			4.615		ms
Time slot duration			577		μs
Modulation	GMSK				
Receiver input sensitivity @ ARP Under all propagation conditions according to GSM specification	E-GSM 900	- 102			dBm
	GSM 1800	- 102			dBm
Receiver input sensitivity @ ARP BER Class II < 2.4% @ static input level (no fading)	E-GSM 900		-107		dBm
	GSM 1800		-106		dBm
Length of antenna cable				3	m

6 Full type approval

The Siemens reference setup submitted to type approve MC35i Terminal consists of the following components:

- MC35i Terminal with approved GSM Engine MC35i
- Votronic Handset type
- PC as MMI
- Power Supply: Mains adapter Sphere Design Type FW7207/12

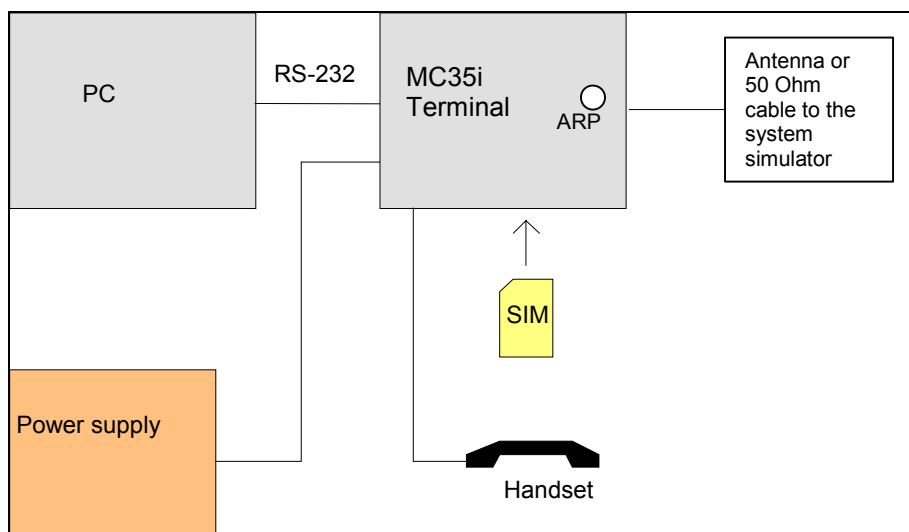

Figure 13: Reference equipment for approval

For ordering information please refer to Chapter 7.

6.1 Restrictions

Later enhancements and modifications beyond the certified configuration require extra approvals. Each supplementary approval process includes submittal of the technical documentation as well as testing of the changes made.

- No further approvals are required for customer applications that comply with the approved MC35i Terminal configuration.
- Extra approval must be obtained for applications using other accessories than those included in the approved MC35i Terminal configuration (handset, power supply, MMI implementation supported by AT commands).

6.2 CE Conformity

The MC35i Terminal meets the requirements of the EU directives listed below.

- R&TTE Directive 1999/5/EG
- LVD 73/23/EEC
- EMC conformity in accordance with Directive 89/336/EEC

6.3 EMC

The MC35i Terminal meets EN 301489-7 requirements of equipment for vehicular and fixed use.

(Note: V_{PLUS} power fail time > 1ms resets the terminal)

7 List of parts and recommended accessories

Description	Supplier	Ordering information
MC35i Terminal	Siemens	Siemens ordering number L36880-N8660-A100
Mounting kit for top/hat rail installation	Sphere Design	Ordering number: 20100 Sphere Design Saarpfalz-Park 17 D-66450 Bexbach / Saar Phone: +49-6826-5200-0 Fax: +49-6826-5200-25 E-Mail: info@spheredesign.de http://www.spheredesign.de
Power supply unit	Sphere Design	Ordering number: 39001 Sphere Design Saarpfalz-Park 17 D-66450 Bexbach / Saar Phone: +49-6826-5200-0 Fax: +49-6826-5200-25 E-Mail: info@spheredesign.de http://www.spheredesign.de
Handset	Votronic	Ordering number: HH-SI-30.3/V1.1/0 Votronic GmbH Saarbrücker Str. 8 D-86386 St. Ingbert Phone: +49-6894-9255-44 Fax: +49-6894-9255-88
Antenna (900 – 1800 MHz)	Märtens	Ordering number: various types available Märtens Systemelektronik GmbH &Co. KG Kablekamp 2 D-30179 Hannover Phone: +49-511-674 95 826 Fax: +49-511-63 63 41 E-Mail: mc-gsm-data@t-online.de http://www.maertens-communication.com
RS-232 cable (9 pin D-Sub)	Tecline	Ordering number: 300574 Tecline Behrener Str. 8 D-66117 Saarbrücken Phone: +49-681-926 78-29 Fax: +49-681-926 78-50
BB35 Bootbox	Siemens	Siemens ordering number: L36880-N8102-A100